

ASSEMBLY INSTRUCTION FOR MOPF-KD5-27888-BW-78"

Note:

- Read instructions carefully.
- Carefully identify each component especially those that are similar.
- Separate and identify each component from the hardware pack and rest each one in its proper location before fastening.
- Do not over tighten the screws or bolts when assembling.



2 Persons

TOOL REQUIRED

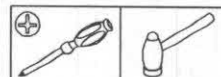

Step 1

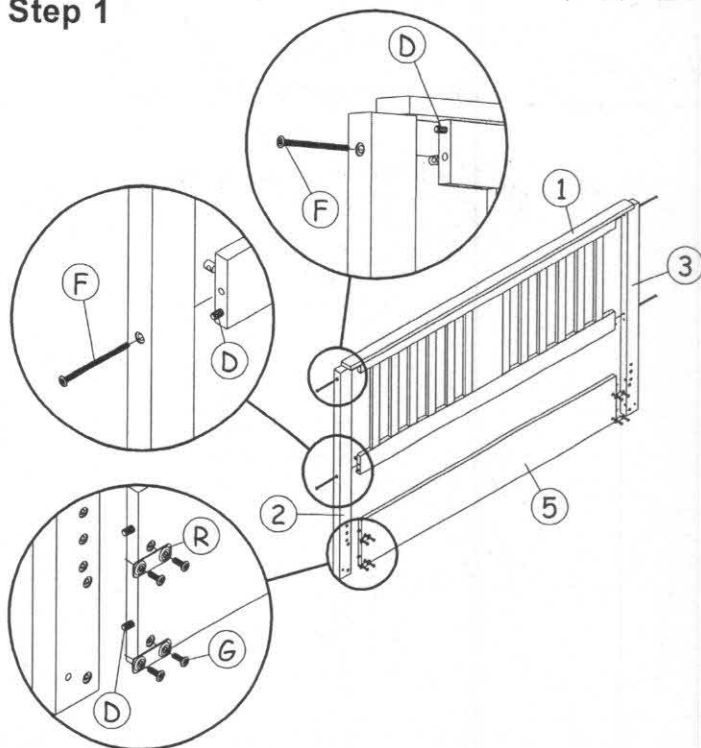

Fix all headboard component as shown

Step 2

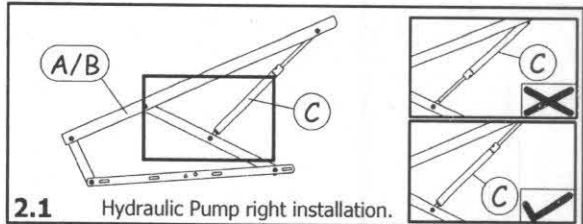

2.2

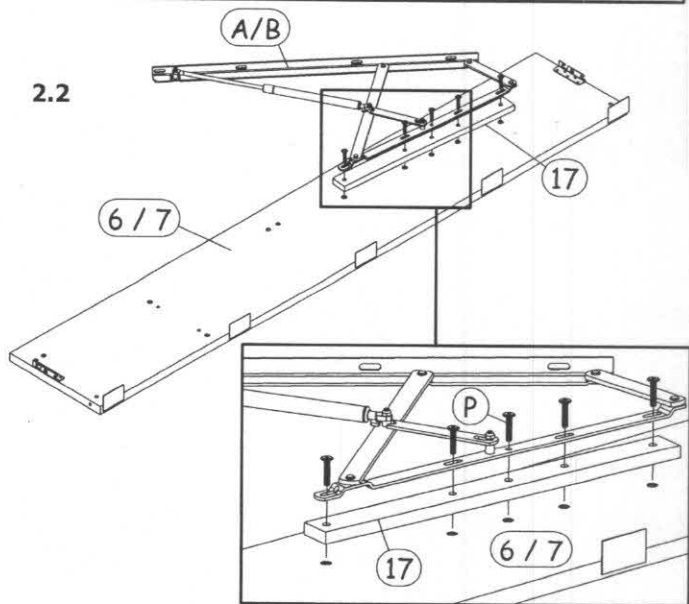

Firstly, fix the hydraulic pump to each hydraulic base as shown in diagram 2.1. Next, fix the left & right hydraulic spacer together with hydraulic base supporter to the both side rails using bolts 'P' as shown in diagram 2.2 and tighten all bolts.

Step 3

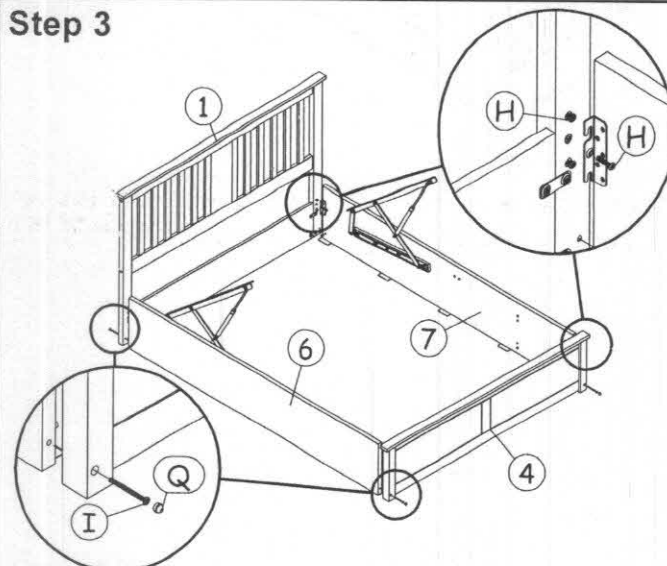

Fix side rails to the headboard and footboard with hardware as shown.

Step 4

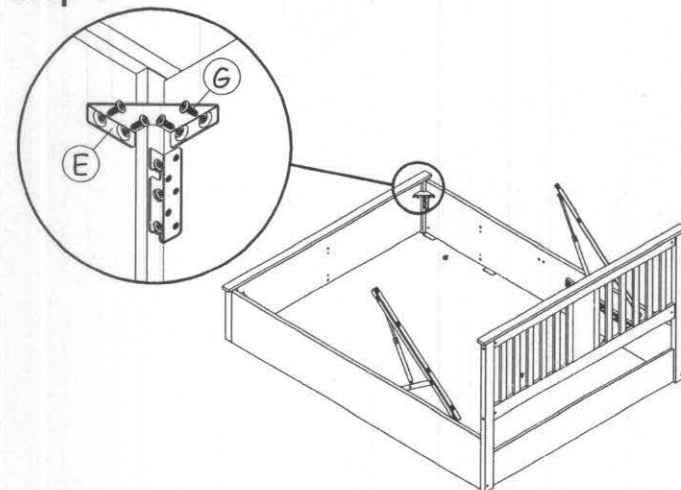

Fix metal corner block 'E' to the edge of footboard and side rails with bolts 'G' as shown.

Step 5

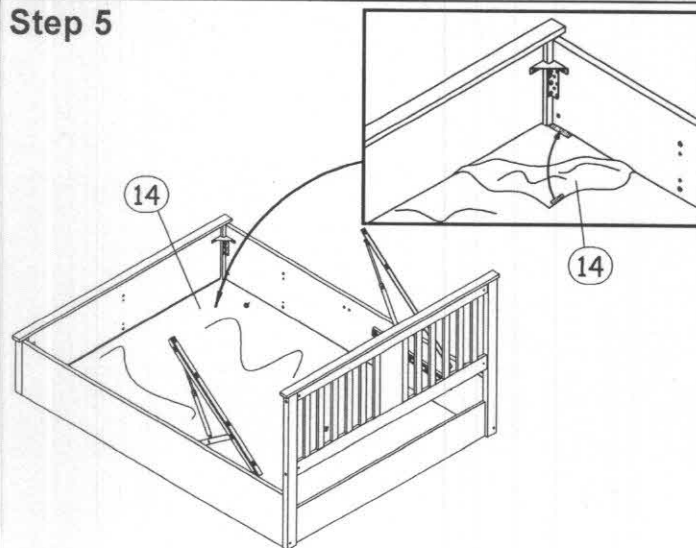

Attach Non-Woven Fabric '14' at the bottom as shown in diagram.

Please follow our assembly instruction procedure for easier assemble.

Step 6

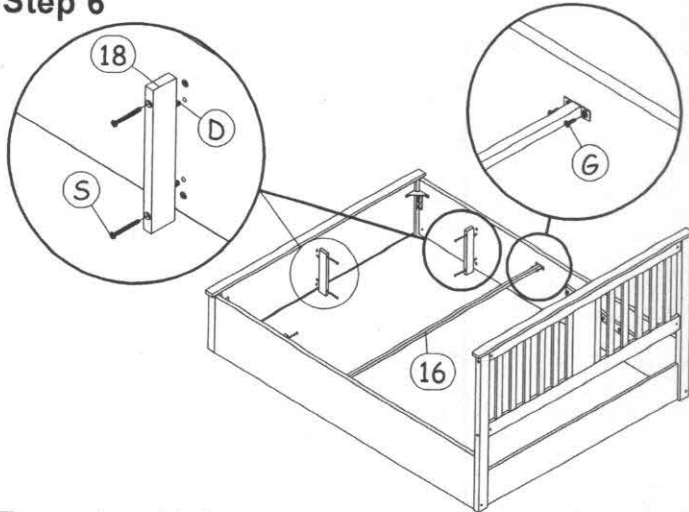

Fix support wood to the side rails and footboard with hardware as shown and follow by centre cross bar.

Step 7

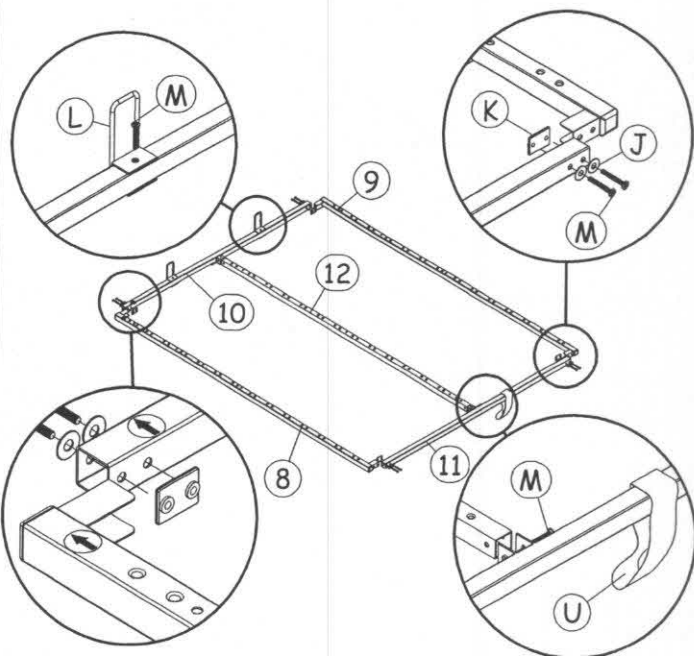

Join together all the bed base parts (8),(9),(10),(11) and (12) using hardware parts **M**. Attach hardware parts **L** using hardware part **M** and then attach hardware part **U** by slot to the part (11) as shown.
Important note: Please assemble follow arrow direction.

Step 8

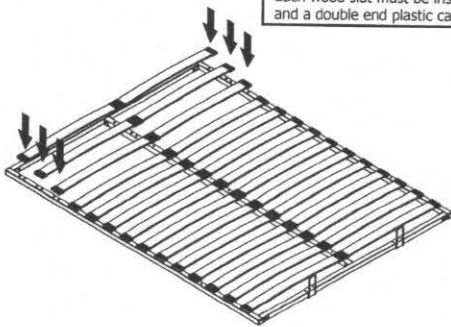
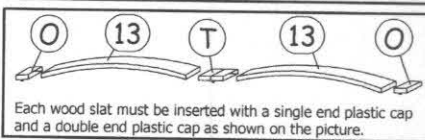

Place wood slats with plastic caps as above drawing. Then, fix it on the bed base by pressing it accordingly to the default holes. Ensure the plastic cap's pin is aimed to the hole.

Step 9

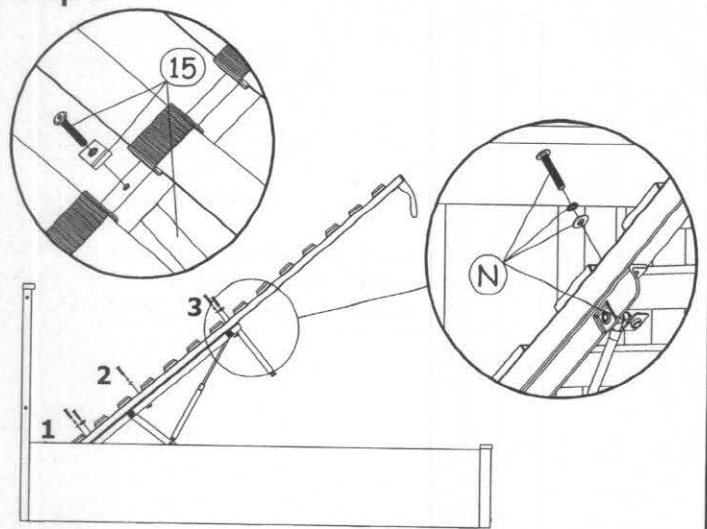

Assemble the bed base on the right & left hydraulic frame and fix bolts starting from '1' to '3' as shown.
Important note : Do not tighten the bolts yet!



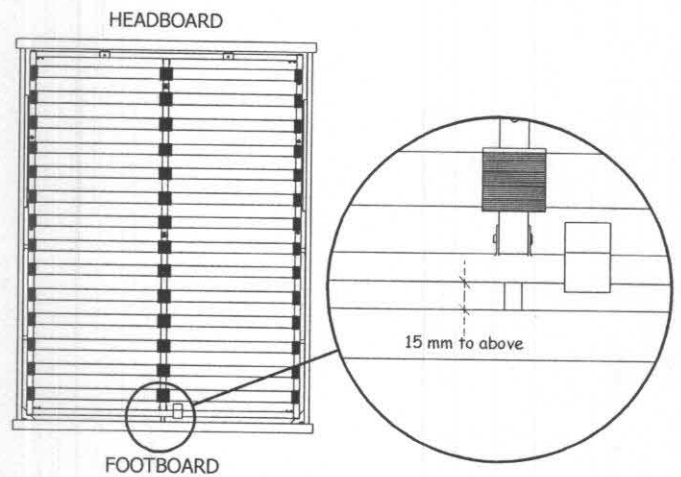







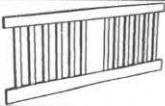

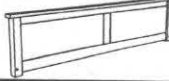

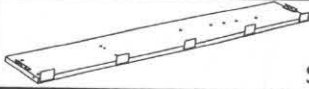
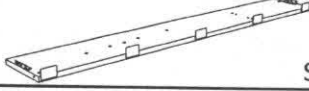

Step 10

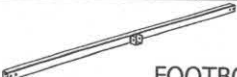

Adjust the bed base, make sure distance with the front footboard approximately 15mm to above gap as shown.
Important note : Tighten all bolts & screws.

Please follow our assembly instruction procedure for easier assemble.

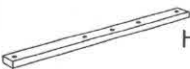
PARTS & HARDWARE LIST FOR MOPF-KD5-27888-BW-78"

PART LIST		
NO.	ITEM	QTY.
1	 HEADBOARD FRAME	1 PC
2	 WOOD POST (L)	1 PC
3	 WOOD POST (R)	1 PC
4	 FOOTBOARD	1 PC
5	 BACK STORAGE PANEL	1 PC
6	 SIDE RAIL (L)	1 PC
7	 SIDE RAIL (R)	1 PC
8	 LEFT SIDE METAL BAR	1 PC
9	 RIGHT SIDE METAL BAR	1 PC
10	 HEADBOARD END METAL BAR	1 PC
11	 FOOTBOARD END METAL BAR	1 PC
12	 CENTER METAL BAR	1 PC
13	 SLAT	28 PCS
14	 NON-WOVEN FABRIC SHEET	1 PC
15	 SUPPORT LEG	2 PCS
16	 CENTRE CROSS BAR	1 PC
17	 HYDRAULIC ARM SPACER	2 PCS
18	 BASE SUPPORT WOOD	3 PCS

HARDWARE LIST		
NO.	ITEM	QTY.
A	 LEFT HYDRAULIC BASE SUPPORT c/w PUMP STOPPER	1 PC

NO.	ITEM	QTY.
B	 RIGHT HYDRAULIC BASE SUPPORT	1 PC
C	 HYDRAULIC PUMP	2 PCS
D	 WOOD DOWEL 8 x 30	14 PCS
E	 CORNER BRACKET	2 PCS
F	 JCBC BOLT M6 x 100MM c/w BARREL NUT	4 PCS
G	 JCBC BOLT M6 x 15MM	20 PCS
H	 JCBC BOLT M6 x 20MM	12 PCS
I	 JCBC BOLT M6 x 70MM c/w BARREL NUT	4 PCS
J	 FLAT WASHER	8 PCS
K	 WASHER BRACKET	4 PCS
L	 BASE HANDLE	2 PCS
M	 JCBC BOLT M6 x 40MM	12 PCS
N	 M8 x 45MM JCBB BOLT c/w NUT BRACKET, SPRING & FLAT WASHER	6 PCS
O	 SINGLE END PLASTIC CAP	28 PCS
P	 JCBB BOLT M8 x 35MM	10 PCS
Q	 WOOD BUTTON	2 PCS
R	 BRACKET	4 PCS
S	 JCBC BOLT M6 x 60mm	6 PCS
T	 DOUBLE END PLASTIC CAP	14 PCS
U	 BELT HANDLE	1 PC
V	 ALLEN KEY - M6	1 PC
W	 ALLEN KEY - M8	1 PC
X	 M12.8 SPANAR	1 PC

CAUTION : KEEP ALL HARDWARE PARTS OUT OF REACH OF CHILDREN

Please follow our assembly instruction procedure for easier assemble.

" IMPORTANT NOTE "

WHEN THE BED IS BUILT AND THE MATTRESS FRAME IS AT 45 DEGREE
PLEASE PLACE THE MATTRESS ON THE BED.

PLEASE NOTE THAT THE WEIGHT OF THE MATTRESS IS REQUIRED TO
HELP CLOSE THE BED.

TO LOWER THE SLEEPING PLATFORM STAND AT THE FOOT END OF THE
BED AND PUSH SHARPLY
DOWNWARDS USING BOTH HANDS.

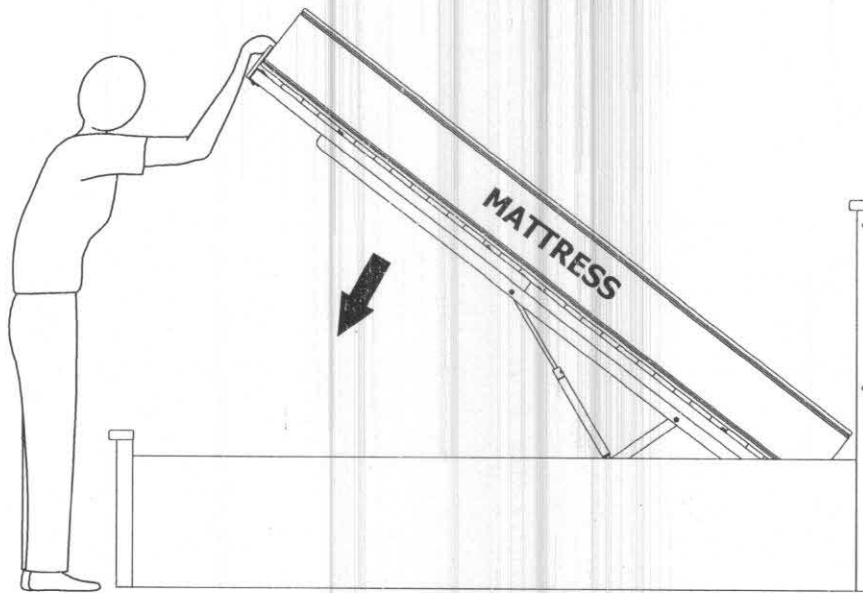

CAUTION :

PLEASE USE HYDRAULIC PUMP STOPPER FOR SAFETY PURPOSE.

